

Luftströmungsrichtung  
min. freier Abstand 1000 mm  
air flow  
min. free distance 1000 mm

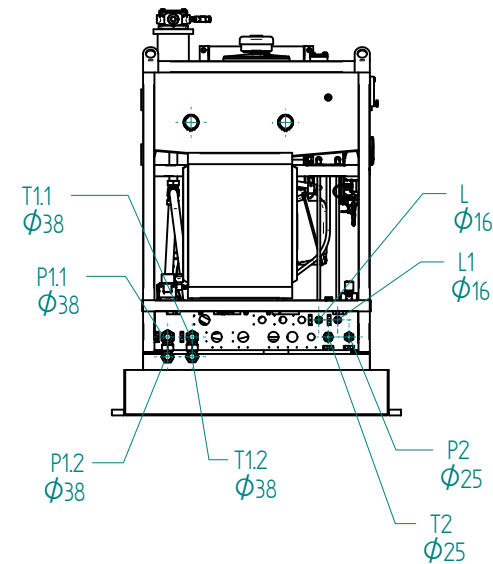
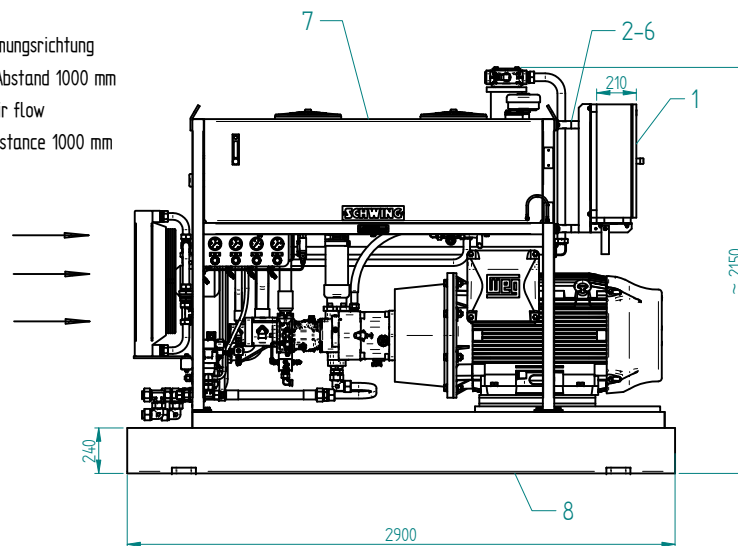

E-Motor / Electric motor  
400/690V- 50 Hz

alle elektrischen Komponenten IP65  
all electrical components IP65

Fundamentbefestigung / Anchoring

Nicht im Lieferumfang enthalten.  
Not incl. in delivery volume (Optional)

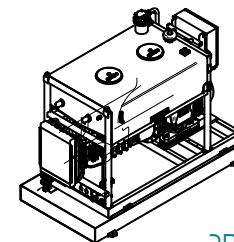
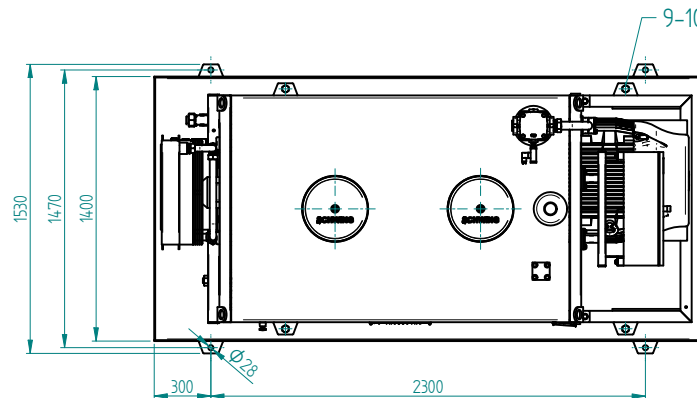

3D  
1:50

Gewichtsangabe ohne Hydrauliköl  
weight information w/o hydraulic oil

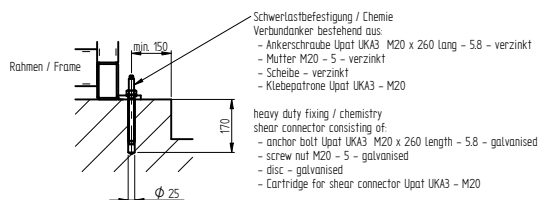

Schutzvermerk DIN 34-1-D Copyright reserved Schwing GmbH	Format / SIZE: A 2	Datum / DATE: 19.07.2012	Name / NAME: Dicks	Sicherheitsteil / SAFETY PART: S2	Benennung / NAME: EHS-Aggr. 800,132 kW A1V0260EP2, LK A1V0260EP2D/A10V045DFR/SMLP361/208S, DBE, H EHS unit 800,132 kW A1V0260EP2, LK A1V0260EP2D/A10V045DFR/SMLP361/208S, DBE, H
Ers. durch / REPL. BY:	Gezeichnet / DRAWN BY:	Gepüft / CHECKED BY:	Normgeprüft / APPROVED BY:	Gewicht / WEIGHT (kg): 2590,000	Maßstab / SCALE: 1:20
Ers. für / REPL. FOR:	Werkstoff / Werkstoff-Nr.: / MATERIAL / MATERIAL CODE:		Nicht abmessen / DO NOT SCALE		
Ung.-Datum/EXPIRY DATE:	Assembly (siehe Stückliste, look at BOM)				

Allgemeintoleranz siehe Werknorm 1.5 / General Tolerances WN-No.: 1.5		
Dokumenteninfosatz-Nr. / DIS NO: 9000354575	Material-Nr. / PART NO: 98359810	
Rev. / REV 00	Datum / DATE 19.07.2012	Name / NAME HDICKS
Blatt-Nr. / SHEET: 1/1		<b>SCHWING</b>